

MTC HC-80

High Capacity Mobile Tank Cleaning System

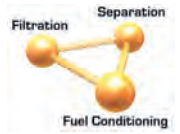

MTC HC-80 High Capacity Mobile Tank Cleaning Systems are used to clean fuel storage tanks and recondition, stabilize and decontaminate Diesel Fuel, Bio-Diesel, Light Oils and Hydraulic Fluids. They offer multi-phase tank cleaning, water & sludge removal and transfer of fuels between tanks to guarantee **Optimal Fuel Quality at All Times**.



MTC HC-80 Systems feature:

- High Capacity Fluid Processing
- Multiple Discharge and Sample Ports for Water Removal and Fuel Transfer
- Large Contaminant Holding Capacity
- Compact Industrial Design
- Tank Cleaning while Reconditioning, Stabilizing, Decontaminating & Drying Fuel

The MTC HC-80 is a four-stage mobile fuel conditioning and tank cleaning system that efficiently removes sludge and water from fuel storage tanks, restoring and optimizing fuel quality in the same operation.

The system is designed as a “fuel/oil dialysis system” that circulates and cleans fuel/oil by pumping it from the tank, processing it through the MTC and back into the tank.

AXI’s mobile tank cleaning systems excel in combining High Capacity Filtration & Water Separation with Compact Design and Low Operating Cost to provide Optimal Fuel Quality for Peak Engine Performance and Reliability.

MTC HC-80 SPECIFICATIONS

Flow Rate	80 GPM
Primary Filter	Carbon Steel Pre-Filter Housing, Quick Release 3-Bolt Swing Cover, Drain Valve & Air Vent, Perforated SS Strainer Basket 9/64" (3.5 mm) for use with Filter Bags
Liner & Filter Bags	Replaceable Filter Bags 1-1500 μ
Secondary Filter	Carbon Steel Filter Housing, quick Release 3-Bolt Swing Cover Drain Valve & Air Vent
Filter Cartridges	Particulate Filter 2-30 μ Water Block Filters 5, 10, 30 μ Absolute Microglass Filters 3-10 μ
Water Separator	RCM 1500 with Drain Valve & Air Vent
Fuel Conditioner	LG-X 4000
Smart Filtration Controller	SFC-55HC
Instrumentation & Automation	Vacuum Gauges on Primary Filter Pressure Gauge on Pump Discharge Pressure Gauges on Secondary Filter AXI Watect 550 Water Sensor Alarm Module
Pump Power/ Air Requirements	2 HP Self-Priming Centrifugal Pump 208/230V 60Hz 20A 2" Ports (NPT) Viton Seals
Ports	One Suction, Multiple Discharge & Sample Ports
Connectors	Cam & Groove Fittings and Covers
Hoses	2", 25 ft Clear Suction Hose 2", 25 ft Discharge Hose
Skid	Powder Coated Carbon Steel Lifting Eyes & Forklift Channels Drip Tray with Drain
Dimensions	36" x 45" x 58" (91 x 114 x 147 cm)
Weight	563 lbs
Not for use with fluids that have a flash point below 100°F.	



The MTC HC-80 is equipped with a self-priming centrifugal pump and a direct-coupled electric motor rated at 80 GPM. The system's maximum flow rate depends on factors such as: suction lift, discharge head, hose length & diameter, pressure drop over the primary/secondary filters and separator.

The system is equipped with an adjustable vacuum switch on the input side of the pump. Vacuum value readings reaching 15" HG vacuum indicate a clogged primary filter or suction line flow restriction/excessive lift due to excessive debris in the primary filter. This will result in pump shutdown and activate the high vacuum alarm.

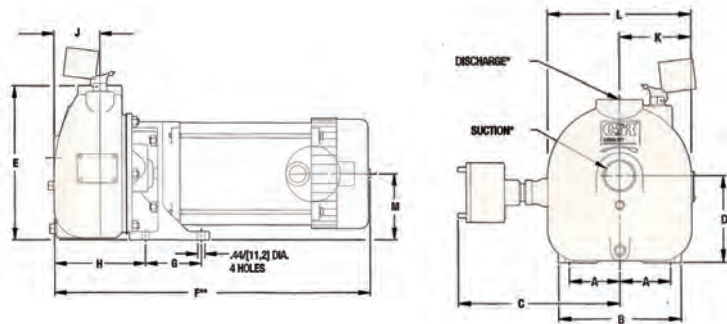
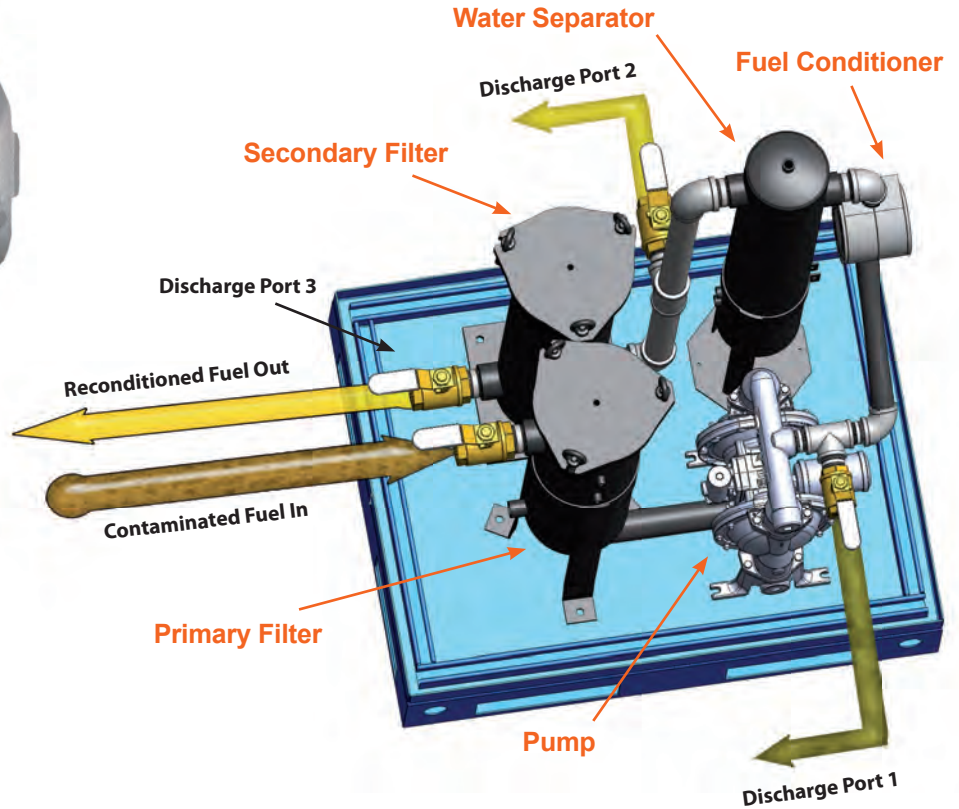

MTC HC-80 PUMP SPECIFICATIONS

Pump	Cast Iron Pump with Viton Seals Handles Solids up to 3/8" Self-Priming to 20ft Max 31 PSI
Motor	2 HP Single Phase
Power	280V 60Hz 220V 50Hz 20 AMP circuit required 11 Full Load Amps
Ports	2" NPT
Dimension	7 x 21 x 9x3-3/4" (18 x 53 x 25 cm)
Weight	101 lbs (45.8 kg)
Material	Cast Iron

MTC HC-80 PUMP CURVE

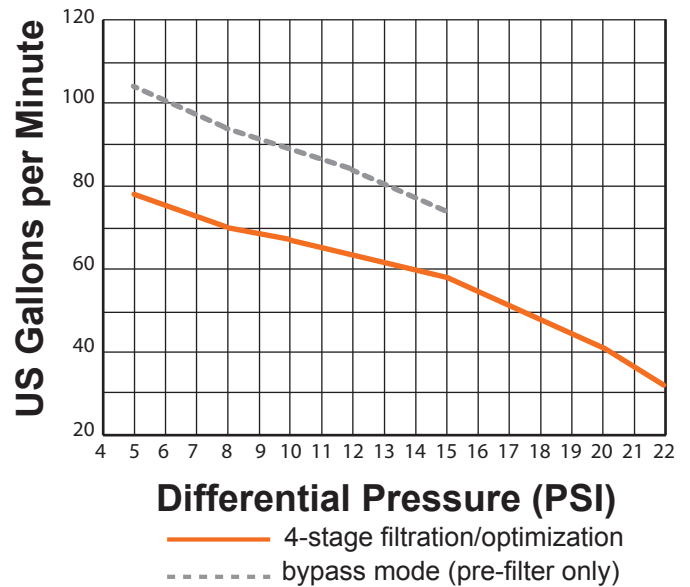

+1-239-690-9589
1-877-425-4239 Toll Free
www.AXIFuelConditioning.com

Wherever fuel is being used or stored

Automation

The SFC-55MTC is a fully automated Smart Filtration Controller with digital text readout of operating & alarm status. It provides an instant visual status report of system power, pump operation and alarms for high pressure, high vacuum and high water levels.

Installed on the MTC HC-80, the controller is equipped with a pendant power ON/OFF switch for remote control and a highly visible strobe light alarm.

Available Options

- Digital Flow Meter
- Additional Hoses
- Sample Ports
- Skid Casters
- Spill Prevention Berms



Digital Flow Meter

The digital flow meter is an excellent tool to monitor flow rate and system performance as well as count the amount of liquid that has been processed.

Spill Prevention Berm

Heavy duty, portable and reusable spill prevention berms are recommended to avoid accidental fluid leakage into the environment.

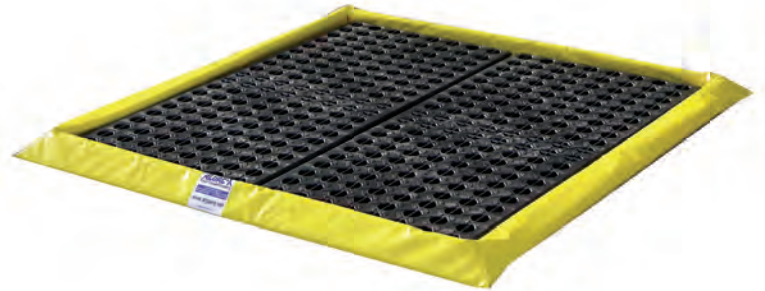

AFC-705 Fuel Catalyst is a unique and powerful, broad-spectrum fuel additive concentrate for use in Diesel, Biofuels, Gasoline, Kerosene and HFO. Including AFC-705 as part of a preventative fuel maintenance program, in combination with good housekeeping, will stabilize your fuel, prevent sludge build-up and eliminate the need for expensive and toxic biocides.

AFC-705 features:

- Cleans Fuel, Storage Tanks & Injection systems
- Improves Combustion, Lowers Emissions & Fuel Consumption
- Removes & Prevents Carbon Build Up and Corrosion
- Adds Lubricity and Inhibits Corrosion
- Extends Lube Oil & Equipment Life
- Optimizes Engine, Generator & Boiler Efficiencies
- Reduces Harmful Emissions, Soot & Particulates (CO, HCs, NOX, SOX, VOCs, Carbonyls, PAH)